

Date :  
Événement :  
Pilote :

Moteur :  
Embrayage :  
Échappement :  
Différentiel :  
Carrosserie :

Piste :  
Aspect :  
Grip :  
Conditions :  
T° Air :  
T° Piste :  
Pneus AV-GA: DR:  
Pneus AR-GA: DR:

### TRAIN AR

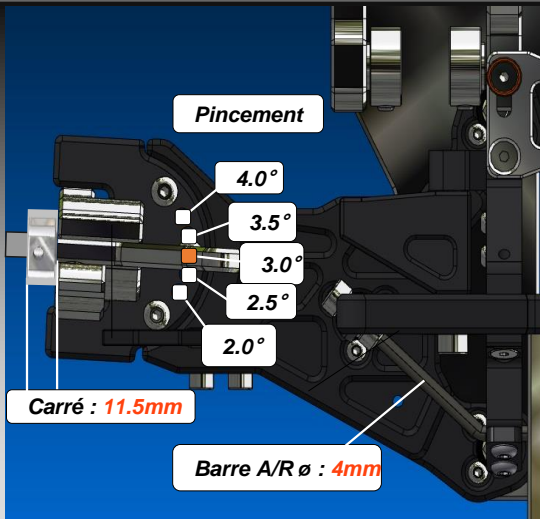
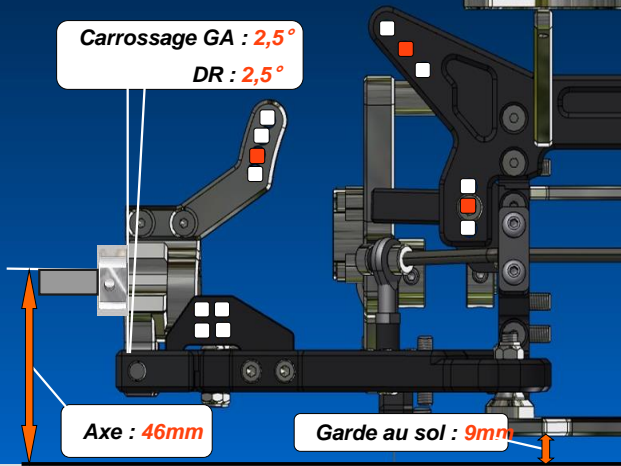

Ressort: ORANGE

Huile : 4000

Nb trous Piston : 6

øTrous Piston : 1.2

### TRAIN AV

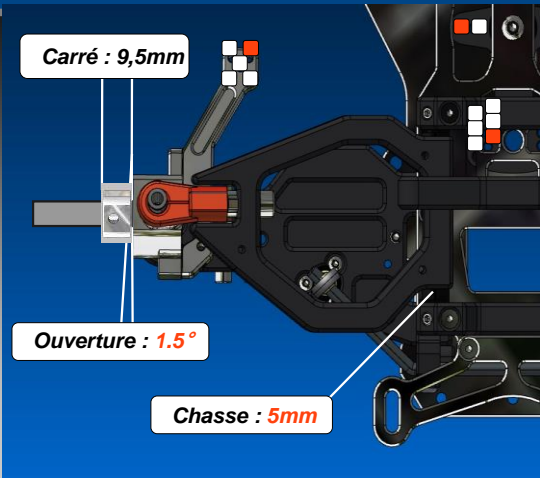
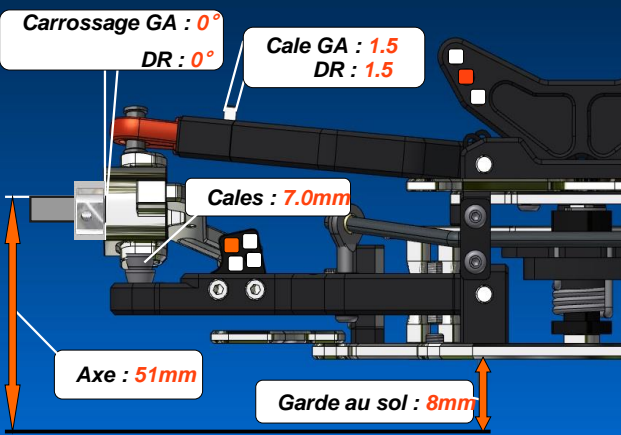

Ressort: Blanc

Huile : 8000

Nb trous Piston : 6

øTrous Piston : 1.2

### TRANSMISSION

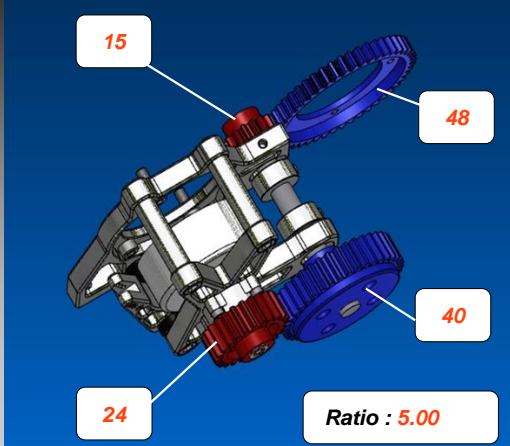

### RATIOS

48	15	41	23	5,70
48	15	40	23	5,57
48	15	41	24	5,47
48	15	39	23	5,43
48	16	41	23	5,35
48	15	40	24	5,33
48	15	41	25	5,25
48	16	40	23	5,22
48	15	39	24	5,20
48	16	41	24	5,13
48	15	40	25	5,12
48	16	39	23	5,09
48	16	40	24	5,00

### Ressorts AR

- JAUNE - ø2.5 / 8
- GRIS - ø2.6 / 8
- VERT F - ø2.65 / 8
- NOIR - ø2.7 / 9
- BLEU - ø2.7 / 8.5
- VERT - ø2.7 / 8
- + ORANGE - ø2.75 / 8

### Ressorts AV

- OR - ø2.8 / 8
- ROUGE - ø2.9 / 8
- BLANC - ø3.0 / 8
- + ROSE - ø3.2 / 8

### NOTES